

STI Polycarbonate Enclosures



NOW AVAILABLE WITH AIRCON AND/OR HEATER FACILITY (selected models)

▶ Product overview

Polycarbonate Enclosures help protect against vandalism and accidental damage. This range of multipurpose transparent polycarbonate enclosures is designed for the protection of fire and security control panels and other electronic equipment.

Combining a tough rugged construction with stylish design, the series offers excellent protection for a wide range of equipment. The enclosures protect against vandalism, accidental damage and the environment whilst ensuring all round visibility and immediate access.

▶ How it works

External mounting tabs allow the enclosures to be easily installed on to any wall surface, providing protection without the need to change the location of the equipment. They come complete with mounting accessories and tamperproof screws.

For additional security and to deter misuse and theft, the enclosures can be fitted with a security alarm or sounder/strobe device.

▶ Key features

- **General Information :**
 - Polycarbonate enclosures help protect against vandalism and accidental damage.
 - Three year guarantee against breakage of polycarbonate in normal use (one year on electromechanical and electronic components).
- **Design :** Protects control panels located in areas where the environment conditions are extreme.
- **Construction :** Tough polycarbonate housing can withstand the severest of knocks.
- **Installation :**
 - External mounting tabs allow the enclosure to be easily installed on to any wall surface.
 - Supplied with backplate.
 - Polycarbonate tested -40°C (-40°F) to 49°C (120°F).
- **Options :**
 - Available with or without a 95 dB alarm, powered by a 9V PP3 battery.
 - Includes thumb lock or key lock.
 - Can be supplied with optional alarm.

▶ Models available

- **STI-7520 :** Weatherproof Clear Polycarbonate Enclosure with key lock
- **STI-7521 :** Weatherproof Clear Polycarbonate Enclosure with thumb lock
- **STI-7522 :** Weatherproof Clear Polycarbonate Enclosure with key lock and audible security device
- **STI-7523 :** Weatherproof Clear Polycarbonate Enclosure with thumb lock and audible security device
- **STI-7524 :** Clear Protective Cabinet with sounder/strobe device and key lock
- **STI-7525 :** Clear Protective Cabinet with sounder/strobe device and thumb lock
- **STI-7530 :** Clear Polycarbonate Enclosure with key lock
- **STI-7531 :** Clear Polycarbonate Enclosure with thumb lock
- **STI-7532 :** Clear Polycarbonate Enclosure with key lock and audible security device
- **STI-7533 :** Clear Polycarbonate Enclosure with thumb lock and audible security device
- **STI-7534 :** Clear Protective Cabinet with sounder/strobe device and key lock
- **STI-7535 :** Clear Protective Cabinet with sounder/strobe device and thumb lock
- **STI-7550 :** Extra Large Polycarbonate Enclosure with key lock
- **STI-7551 :** Extra Large Polycarbonate Enclosure with thumb lock
- **STI-7552 :** Extra Large Polycarbonate Enclosure with key lock and audible security device
- **STI-7553 :** Extra Large Polycarbonate Enclosure with thumb lock and audible security device
- **STI-7554 :** Clear Protective Cabinet with sounder/strobe device and key lock
- **STI-7555 :** Clear Protective Cabinet with sounder/strobe device and thumb lock

Accessories:

STI-7530WR : Wire shelf for STI-7530, STI-7531, STI-7532 & STI-7533 (included with the STI-7533AED & STI-7535AED).

▶ **AED Protective cabinets**

- **STI-7531AED** : Supplied with backplate, wire shelf and thumb lock
- **STI-7533AED** : Supplied with thumb lock, audible security device and wire shelf
- **STI-7535AED** : Supplied with thumb lock, wire shelf and sounder/strobe device
- **STI-7551AED** : Supplied with thumb lock
- **STI-7553AED** : Supplied with backplate, audible security device and thumb lock
- **STI-7555AED** : Supplied with sounder and thumb lock

▶ **Models available with AC & Heater facility**

- **STI-7550AC** : Polycarbonate Protective Cabinet with Aircon facility
- **STI-7550AH** : Polycarbonate Protective Cabinet with Aircon and Heater facilities
- **STI-7551AC** : Polycarbonate Protective Cabinet with Aircon facility
- **STI-7551AH** : Polycarbonate Protective Cabinet with Aircon and Heater facilities

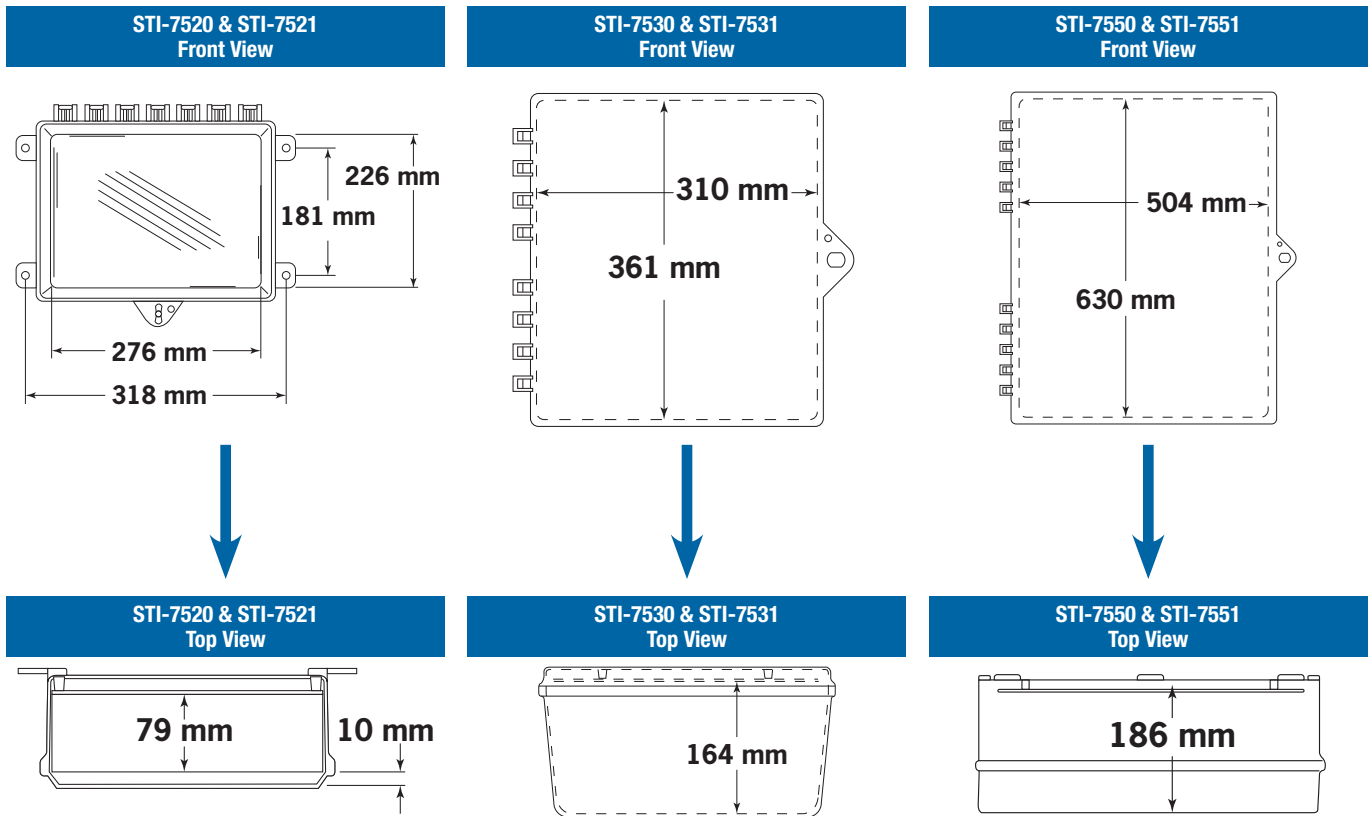

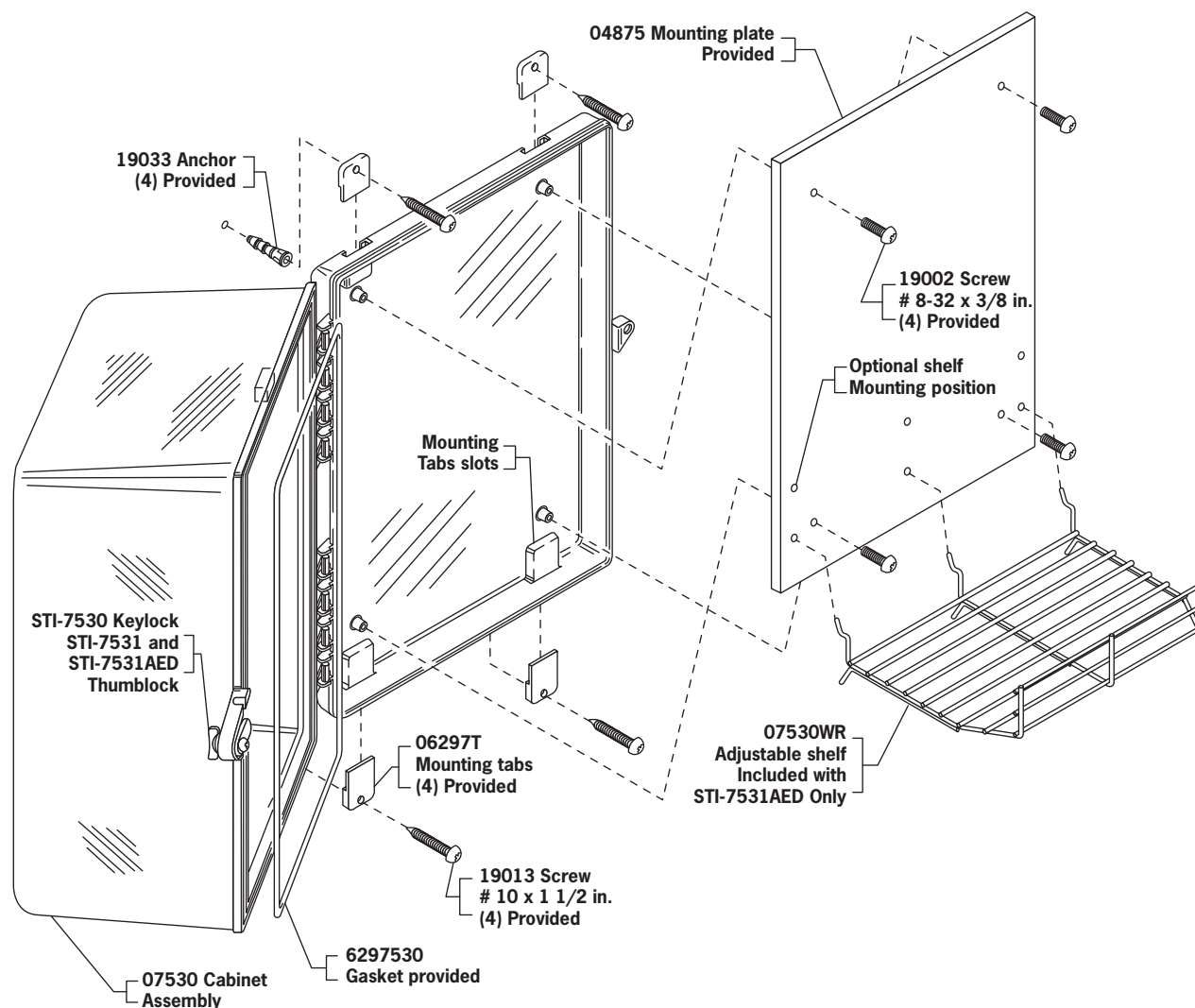

Front view

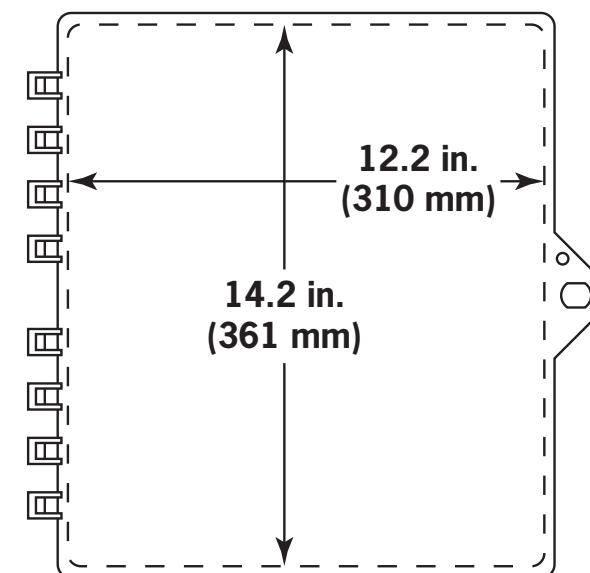

Top view

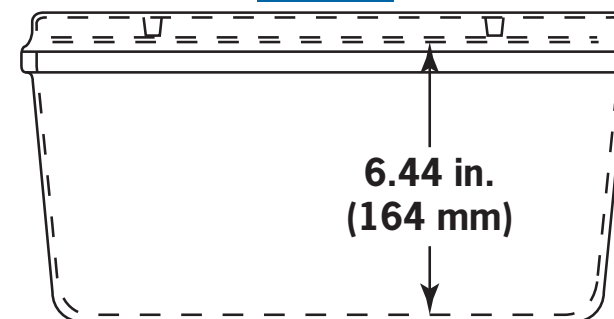

► Cleaning instructions

1. Rinse cover with water to remove abrasive dust and dirt.
2. Wash with soap or mild detergent using a soft cloth. (do not scrub)
3. Rinse once more, the dry with a soft cloth or chamois.
4. To remove grease or wet paint, rub gently with a cloth wetted thoroughly with naphtha, then wash and rinse. (Do not use razor blades).

► Installation of cabinet

1. Insert the (4) 06297T mounting tabs fully into backbox mounting tab slots. Use rubber mallet if necessary.
2. After selecting a suitable location, place cabinet in closed position, against the wall. Mark and drill (4) 1/4 in. diameter holes. Insert the (4) 19033 anchors. Mount cabinet by driving in the four # 10 x 1 1/2 in. screws.
3. For STI-7531AED select one of the two shelf mounting locations, install shelf. Close and lock cabinet.